

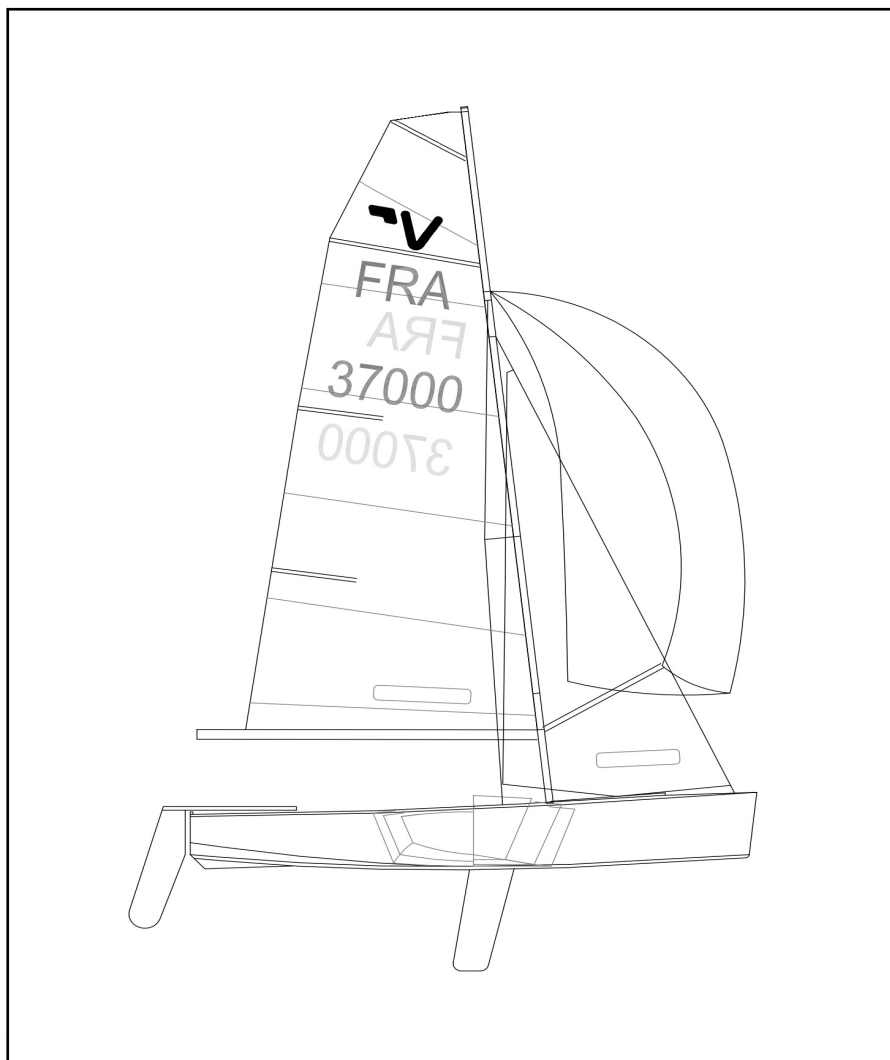

# INTERNATIONAL VAURIEN CLASS RULES 2011



The Vaurien was designed by **Jean Jacques HERBULOT** and was adopted as an International Class by ISAF in 1957

# INTRODUCTION

---

*This introduction only provides an informal background about the VAURIEN class. The International Vaurien Class Rules proper begin on the next page.*

*The VAURIEN is a One-Design class designed by Jean-Jacques Herbulot in 1950. It became an International Class in 1957.*

*VAURIEN hulls, hull appendages, rigs and sails are measurement or manufacturing controlled.*

*VAURIEN hulls, hull appendages, rigs and sails may, after having left the manufacturer, only be altered to the extent permitted in Section C of the class rules.*

*Owners and crew should be aware that compliance with rules in Section C is NOT checked as part of the certification process.*

*Rules regulating the use of equipment during a race are contained in Section C of these class rules, in ERS Part I and in the Racing Rules of Sailing.*

*VAURIEN Class permits In House Certification (IHC) of appendages, rigs and sails ; for hulls IVCA may give authorization in special cases.*

*Builders are strongly advised to clarify any doubt about these class rules before starting construction to avoid the possibility of boats being subsequently considered not complying.*

PLEASE REMEMBER:

THESE RULES ARE CLOSED CLASS RULES WHERE IF IT DOES NOT  
SPECIFICALLY SAY THAT YOU MAY  
THEN YOU SHALL NOT.

COMPONENTS, AND THEIR USE, ARE DEFINED BY THEIR DESCRIPTION.

## PART I – ADMINISTRATION

---

### Section A – General

#### A.1 LANGUAGE

- A.1.1 The official language of the class is English and in case of dispute over translation the English text shall prevail.
- A.1.2 The word “shall” is mandatory and the word “may” is permissive.

#### A.2 ABBREVIATIONS

- A.2.1 ISAF International Sailing Federation  
MNA ISAF Member National Authority  
IVCA International Vaurien Class Association  
CIV Comite International du Vaurien  
NVCA National Vaurien Class Association  
ERS Equipment Rules of Sailing  
RRS Racing Rules of Sailing  
MF Measurement Form

#### A.3 AUTHORITIES

- A.3.1 The international authority of the class is the ISAF who has delegated to IVCA the administration of the class; IVCA shall co-operate with ISAF in all matters concerning these **class rules**.
- A.3.2 Neither the ISAF, an MNA, the IVCA, an NVCA, a certification authority, or an official measurer are under any legal responsibility in respect of these **class rules** and the accuracy of measurement, nor can any claims arising from these be entertained.
- A.3.3 Notwithstanding anything contained herein, the **certification authority** has the authority to withdraw a **certificate** and shall do so on the request of the ISAF.

#### A.4 ADMINISTRATION OF THE CLASS

- A.4.1 The Class is administered by the IVCA who may delegate part or all its functions to MNAs or NVCA's, as stated in these Class Rules
- A.4.2 In countries where there is no MNA, or the MNA does not wish to administer the class, its functions, as stated in these **Class Rules**, shall be carried out by the IVCA which may delegate the administration to a NVCA.

#### A.5 ISAF RULES

- A.5.1 These **Class Rules** shall be read in conjunction with the ERS.
- A.5.2 Except where used in headings, when a term is printed in “**bold**” the definitions in the ERS apply and when a term is printed in “*italics*” the definitions in the RRS shall apply

A.5.3 These Rules are complementary to the Building Specification Plans and Measurement Form.

## **A.6 CLASS RULES VARIATIONS**

A.6.1 At Class Events – see RRS 89.1.d) – ISAF Regulation 26.5(f) applies. At all other events RRS 86 applies.

## **A.7 CLASS RULES AMENDMENTS**

A.7.1 Amendments to these **Class Rules** are subjected to the approval of the ISAF in accordance with the ISAF Regulations.

## **A.8 CLASS RULES INTERPRETATIONS**

A.8.1 Interpretations of these **Class Rules** shall be made in accordance with the ISAF Regulations.

## **A.9 INTERNATIONAL CLASS FEE AND ISAF BUILDING PLAQUE**

A.9.1 The licensed hull builder shall pay the International Class Fee to IVCA that shall convey to ISAF part of it.

A.9.2 ISAF shall, after having received the International Class Fee for the hull, send the ISAF Building Plaque to IVCA that shall forward it to the licensed hull builder accompanied by a measurement form.

## **A.10 SAIL NUMBERS**

A.10.1 Sail numbers shall correspond to the number shown on to the ISAF International Class building plaque except where stated otherwise in these class rules and shall be issued in consecutive order starting from 1

## **A.11 HULL CERTIFICATION**

A.11.1 A **certificate** shall record the following information:

- (a) Class
- (b) **Certification authority**
- (c) Sail number issued by the **certification authority**
- (d) Owner
- (e) **Hull** identification
- (f) Builder details
- (g) Date of issue of initial **certificate**
- (h) Date of issue of **certificate**

## **A.12 INITIAL HULL CERTIFICATION**

A.12.1 For a **certificate** to be issued to a **hull** not previously **certified**:

- (a) **Certification control** shall be carried out by an **official measurer** who shall complete the appropriate documentation.
- (b) The documentation and **certification** fee if required shall be sent to the **certification authority**.

- (c) Upon receipt of a satisfactorily completed documentation and **certification** fee, if required, the **certification authority** may issue a **certificate**.

### **A.13 VALIDITY OF CERTIFICATE**

A.13.1 A **hull certificate** becomes invalid upon:

- (a) the change to any items recorded on the **hull certificate** as required under A.11.,
- (b) the date of expiry,
- (c) withdrawal by the **certification authority**,
- (d) the issue of a new **certificate**.

### **A.14 HULL RE-CERTIFICATION**

A.14.1 The **certification authority** may issue a **certificate** to a previously certified **hull**:

- (a) when it is invalidated under A.13.1 (a) or (b), after receipt of the old **certificate**, and **certification** fee if required,
- (b) when it is invalidated under A.13.1 (c), at its discretion,
- (c) in other cases, by application of the procedure in A.12.

### **A.15 RETENTION OF CERTIFICATION DOCUMENTATION**

A.15.1 The **certification authority** shall:

- (a) retain the original documentation upon which the current **certificate** is based,
- (b) upon request, transfer this documentation to the new **certification authority** if the **hull** is exported.

## Section B – Boat Eligibility

For a **boat** to be eligible for *racing*, it shall comply with the rules in this section.

### B.1 CLASS RULES AND CERTIFICATION

B.1.1 The **boat** shall:

- (a) be in compliance with the **class rules**,
- (b) have a valid hull **certificate**,
- (c) have valid **certification marks** as required.

### B.2 BUOYANCY CHECKS

B.2.1 The hull **certificate** shall carry a satisfactorily buoyancy check confirmation.

B.2.2 A Race Committee may require that a **boat** shall pass a buoyancy test in accordance with **Appendix H1**.

### B.3 CLASS ASSOCIATION MARKINGS

B.3.1 A valid Class Association marking, as required by NVCA or the IVCA shall be affixed to the **hull** in a conspicuous position.

B.3.2 **Sails** may carry a Class Association Sail Label or button.

## PART II – REQUIREMENTS AND LIMITATIONS

---

The **crew** and the **boat** shall comply with the rules in Part II when *Racing*. In case of conflict Section C shall prevail.

The rules in Part II are **closed class rules**. **Certification control** and **equipment inspection** shall be carried out in accordance with the ERS except where varied in this Part.

### Section C – Conditions for Racing

#### C.1 GENERAL

##### C.1.1 RULES

- (a) RRS 50.4 shall not apply,
- (b) The ERS Part I – Use of Equipment shall apply.

#### C.2 CREW

##### C.2.1 LIMITATIONS

- (a) The **crew** shall consist of two persons,
- (b) During an event, a **crew** member shall not be substituted unless authorized by the Race Committee,
- (c) Junior **crew** shall be less than 19 years old before the 1<sup>st</sup> of January on the year of the competition.

#### C.3 PERSONAL EQUIPMENT

##### C.3.1 MANDATORY

- (a) The **boat** shall be equipped with **personal buoyancy** for each crew member to the minimum standard ISO 12402-5 (Level 50), EN 393 :1995 (CE 50 Newtons), or USCG Type III, or AUS PFD 1. Alternative or additional standards may be prescribed in the Notice of Race or sailing instructions,

##### C.3.2 TOTAL WEIGHT

The total weight of worn clothing and equipment shall comply with current version of RRS rule 43 measured according to RRS, appendix H.

#### C.4 ADVERTISING

##### C.4.1 LIMITATIONS

Advertising shall only be displayed in accordance with the ISAF Advertising Code (see ISAF Regulation 20).

#### C.5 PORTABLE EQUIPMENT

##### C.5.1 MANDATORY

- (a) FOR USE
  - (1) One hand bailer or bucket.

## (b) NOT FOR USE

- (1) Towing rope minimum 12m long of not less than 8mm in diameter attached to **hull** and to anchor when the latter is required by the Notice of Race.
- (2) One paddle minimum weight 0,250kg and a minimum length of 800mm.
- (3) One anchor of not less than 2kg in weight, when required by the Notice of Race.

## C.5.2 OPTIONAL

## (a) FOR USE

- (1) Electronic or mechanical timing devices.
- (2) One magnetic or electronic compass.
- (3) Water bottle holders.
- (4) Non electronic wind indicators.

## (b) NOT FOR USE

- (1) Mooring line.
- (2) Spare parts such as blocks, shackles, ropes, etc.

**C.6 BOAT**

## C.6.1 WEIGHT

No weight limitations apply to the fully rigged **boat**.

## C.6.2 BUOYANCY

The owner is responsible at all times for the buoyancy and for ensuring that at intervals of not more than 12 months the buoyancy is tested according to Appendix H and declaration endorsed by an **equipment inspector**. If in doubt regarding compliance with B.2.1 an **equipment inspector** may order a buoyancy test, afterwards checking the buoyancy tanks for significant leakage. If the buoyancy is deemed unsatisfactory, the **certificate** shall be withdrawn and not return until satisfactory remedial measures have been taken.

## C.6.3 FITTINGS

- (a) The overall numbers of sheaves, cleats, hooks, swivels and levers in the **boat** is limited as follows:

	Minimum	Maximum
Sheaves, single or assembled in blocks		18
Cleats and clam cleats		13
Ratchet block		1
Hooks		7
Swivels		4
Lever		1
Horn cleats		3



- (b) Thimbles, rings, eye plates and fairleads are not restricted. The distribution of these fittings within the permitted mandatory and optional equipment is optional unless stated otherwise in these **class rules**.
- (c) Sheaves as mentioned in C.6.3 (a) comprise any fitting or device including a rotating part used as a sheave.

## C.7 HULL

### C.7.1 MODIFICATIONS AND MAINTENANCE AND REPAIR

- (a) The parts of the **hull** listed in D.1 as supplied by the licensed builder shall not be altered in any way except as permitted by these **class rules**,
- (b) Routine maintenance such as small repairs, painting, sanding and polishing is permitted without re-measurement and re-certification,
- (c) If any **hull** is repaired in any other way than described in C.7.1 (b) an **official measurer** shall verify that the external shape comply with these class rules and that no substantial advantage has been gained as a result of the repair. The **official measurer** shall note it on the **certificate** and describe the details of the repair,
- (d) Non-slip material, tape and low-friction material not exceeding 4mm in thickness may be applied to the **hull**,
- (e) Local reinforcement for fittings and fastenings are permitted,
- (f) Holes not bigger than necessary for the installation of fittings in the **hull** is permitted provided that the result is watertight.

### C.7.2 FITTINGS

#### (a) USE

The type and dimensions of the fittings are mandatory or optional as stated in these **class rules**. The following restrictions apply:

- (1) Hand hole covers and drainage plugs shall be kept in place at all times when racing.
- (2) Fairleads for the **headsail** sheets shall be fixed to the **hull**. A piece of any material maximum 10mm thick may be used between fairlead and **hull**.
- (3) Cleats for the **headsail** sheets may be placed on brackets placed inside the side deck.
- (4) Cleats for all sheets shall be fixed in the **hull**.

## C.8 HULL APPENDAGES

### C.8.1 MODIFICATIONS AND MAINTENANCE AND REPAIR

- (a) Routine maintenance such as small repairs, painting, sanding and polishing is permitted without re-measurement and re-**certification**.

### C.8.2 LIMITATIONS

- (a) Only one **centreboard** and one **rudder** shall be used during an event, except when a **hull appendage** has been lost or damaged beyond repair. A replacement shall be approved by the Race Committee.

### C.8.3 CENTREBOARD

#### (a) USE

- (1) The **centreboard** shall be led up or down as wished by the crew.
- (2) The **centreboard** may be hold in the centreboard case by any wedges or any shock cord.

### C.8.4 RUDDER AND TILLER

#### (a) USE

- (1) The rudder blade shall be in its fully lowered position when *racing*.
- (2) Type and materials of tiller and tiller extension are optional.
- (3) The **rudder** shall be fitted to the **hull** in such a manner that it will not detach from the **hull** if the **boat** capsizes.
- (4) The distance between the transom and the rudder head when set in the rudder fittings as shown in C.8.4.1 shall be between 30mm and 40mm.
- (5) The deepest point of the rudder shall be within an area formed between two circles with centre at the intersection point of the water line and the leading edge of the rudder blade with a maximum radius of 684mm and a minimum of 634mm as shown on diagrams C.8.4.1.
- (6) The position of the **rudder** is optional as shown in C.8.4.1

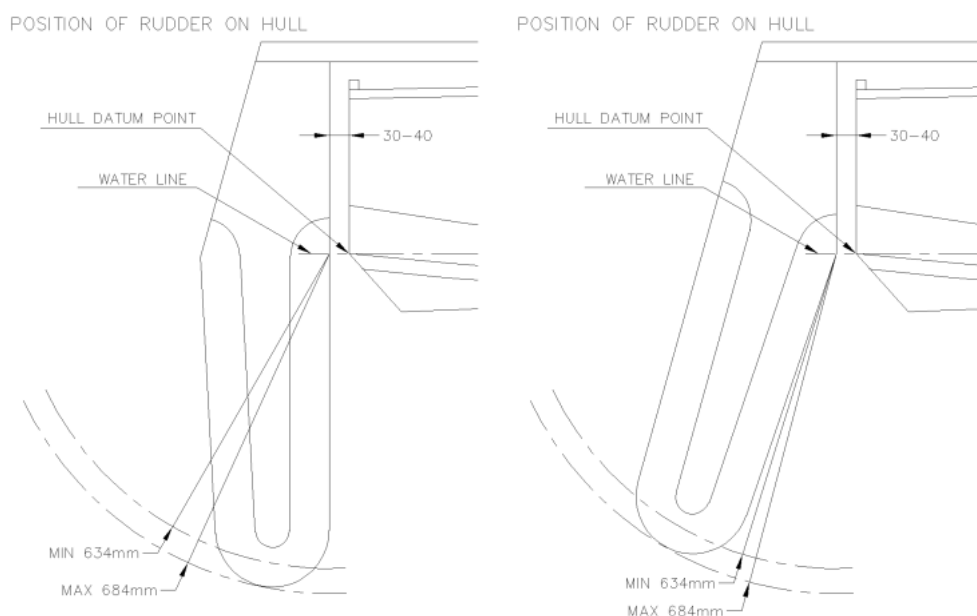

C.8.4.1 RUDDER POSITION ON HULL

**C.9 RIG****C.9.1 MODIFICATIONS AND MAINTENANCE**

- (a) Routine maintenance such as changing lines and/or cables is permitted without re-measurement and re-**certification**.

**C.9.2 LIMITATIONS**

- (a) Only one set of **spars** and standing **rigging** shall be used during an event, except when an item has been lost or damaged beyond repair. A replacement shall be approved by the Race Committee.

**C.9.3 MAST****(a) USE**

- (1) The **spar** shall be stepped in the mast step in such a way that the heel shall not be capable of moving more than 5mm in any direction.
- (2) Rotating **masts** are prohibited.
- (3) The fore and aft bend of the **mast spar** may be controlled at the mast partners by any system.
- (4) The mast heel position shall not be adjusted when *racing*.
- (5) **Spreaders**, if used, may be adjustable but shall not be adjusted while *racing*.
- (6) The **Mast Datum Point** shall be situated below the upper face of the mast thwart.

**C.9.4 BOOM****(a) DIMENSIONS**

	Minimum	maximum
<b>Outer Point Distance</b>		2200 mm

**(b) USE**

- (1) The **boom spar** shall be inserted into the gooseneck fixed to the **mast**.
- (2) The **boom spar** shall be set in accordance with ERS B.7.1

**C.9.5 SPINNAKER POLE****(a) USE**

- (1) When in use the **spar** shall be inserted into the fitting fixed to the fore face of the **mast** for the spinnaker or into the fitting to keep the **headsail** in position.
- (2) Only one spinnaker pole may be carried aboard when *racing*.

**C.9.6 STANDING RIGGING****(a) USE**

- (1) **Rigging** links and rigging screws shall not be adjusted while *racing*.
- (2) The **shrouds** shall not be adjusted while *racing*.
- (3) Shock-cord may be fitted to the forestay.

- (4) The **forestay** under tension shall prevent the **mast** from disengaging from the mast partners. To meet this requirement the widest section of the **mast** shall be within the mast partners when the mast rakes under its own weight and the forestay comes under tension.

#### C.9.7 RUNNING RIGGING

##### (a) USE

- (1) No **running rigging** shall go inside the **mast**. For the purpose of this rule the groove or track for the **mainsail** is considered as being outside the **mast**.
- (2) The **mainsail** and **headsail halyards** when tensioned, shall be secured to the **hull** or to the **mast** below the **lower limit mark**.
- (3) The way the **mainsail**, **headsail** and spinnaker sheets are led is optional.
- (4) The **spinnaker pole** topping lift and downhaul may be led as wished by the crew.
- (5) The kicking strap may be led as wished by the crew.
- (6) The **mainsail** clew outhaul and cunningham control may be led as wished by the crew.

#### C.10 SAILS

##### C.10.1 MODIFICATIONS, MAINTENANCE AND REPAIR

- (a) **Sails** shall not be altered in any way except as permitted by these **class rules**.
- (b) Routine maintenance such as sewing, patching and mending is permitted without re-**measurement** and re-**certification**.

##### C.10.2 LIMITATIONS

- (a) Not more than one **mainsail**, one **headsail** and one spinnaker shall be used during an event, except when a **sail** has been lost or damaged beyond repair. A replacement shall be approved by the Race Committee.

##### C.10.3 MAINSAIL

##### (a) IDENTIFICATION

- (1) The national letters and sail numbers shall comply with the RRS except where prescribed otherwise in these **class rules**.
- (2) Competitors may use the sail number of any **hull** owned by them, on any boat chartered by them.

##### (b) USE

- (1) The **sail** shall be hoisted on a **halyard**. The arrangement shall permit hoisting and lowering of the **sail** at sea whilst afloat.
- (2) The **sail** shall be set in accordance with ERS B.9.1.
- (3) **Luff** and **foot** bolt ropes or slides shall be inside the **spar** grooves or tracks.

- (4) Battens shall be fitted into their respective **batten pockets** when *racing*, except in the case of accidental loss.

#### C.10.4 HEADSAIL

##### (a) USE

- (1) The **headsail** shall be hoisted and lowered on a **halyard**. The arrangement shall permit the hoisting and lowering of the **sail** at sea whilst afloat.

#### C.10.5 SPINNAKER

##### (a) IDENTIFICATION

The sail numbers shall comply with the RRS Appendix G.

##### (b) USE

- 1) The spinnaker shall be hoisted on a **halyard**. The arrangement shall permit the hoisting and lowering of the **sail** at sea whilst afloat.

## Section D – Hull

### D.1 PARTS

#### D.1.1 MANDATORY

- (a) **Hull** shell,
- (b) Transom
- (c) **Keel**
- (d) **Skeg**
- (e) Foredeck with coamings
- (f) Buoyancy Tanks
- (g) Gunwale Rubbing Strakes
- (h) Side decks
- (i) Bulkheads
- (j) Mast thwart,
- (k) Centreboard thwart,
- (l) Centreboard case

#### D.1.2 OPTIONAL

- (a) Side benches,
- (b) Bilge keels.

### D.2 GENERAL

#### D.2.1 RULES

The **hull** shall comply with the **class rules** in force at the time of initial **certification**.

#### D.2.2 CERTIFICATION

- (a) See Rule A.12..
- (b) An ISAF In-house Certification (IHC) Authorizing Authority may appoint one or more Internal Official Measurers at a builder to measure and certify hulls produced by that builder in accordance with the ISAF IHC guidelines.

#### D.2.3 DEFINITIONS

##### (a) HULL DATUM POINT (HDP)

The **hull datum point** is the intersection of the **hull** centre plane at the transom external surface with the underside of the **hull** surface both extended as necessary as shown in diagram D.2.3.1.

##### (b) FORWARD MEASURING POINT 1 (FMP1)

The forward measuring point 1 (FMP1) is the sheer point on the stem as shown in diagram D.2.3.1.

##### (c) FORWARD MEASURING POINT 2 (FMP2)

The forward measuring point 2 (FMP2) is the intersection of the **hull** centre plane with the lowest point of the stem, excluding the external **keel**, as shown in diagram D.2.3.1.

- (d) The **waterline** is the line formed by the intersection of the outside of the **hull** and the horizontal projection of the line formed by the **hull datum point** and FMP2
- (e) The baseline shall be on the projection of the **hull** centre plane connecting the following points :  
 Point at 155mm below the **hull datum point**,  
 Point at 155mm below **FMP2**.
- (f) All measurements shall be taken parallel or perpendicular to the baseline,

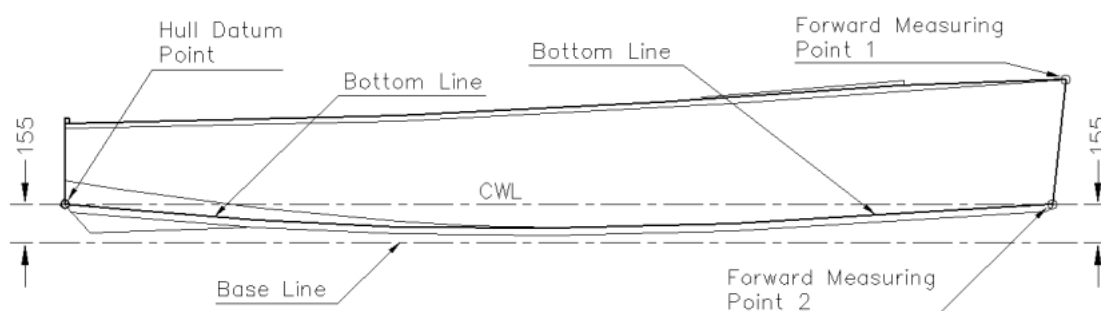

D.2.3.1 HULL DATUM POINTS DIAGRAM

#### D.2.4 IDENTIFICATION

- (a) The **hull** shall carry the ISAF plaque permanently fixed on the starboard internal face of the transom,
- (b) The **hull** shall carry, indelibly marked on the port side of the centreboard case, the sail number in figures not less than 25mm high.
- (c) The **hull** shall carry the label of the current year, as defined by the NVCA regulations, permanently fixed on the port side of the transom.

#### D.2.5 BUILDERS

- (a) The **hull** shall be built by a builder licensed by IVCA,
- (b) The **hull** may be built by bona fide amateur builders licensed by IVCA,
- (c) All moulds shall be approved by IVCA after consultation with the MNA and the NVCA,
- (d) Templates used for **certification control** of **hull** shall be approved by the IVCA.

## D.2.6 MATERIALS

- (a) The **hull** shall be built from one or more of the following options:
- Wood and/or plywood
  - Glass reinforced plastic (GRP) composed of E-Glass fibre for reinforcement and or Polyester or polyvinyl resins as laminating agent
  - Composites combining GRP as defined above for skin and for core Polyvinyl chloride (PVC) closed-cell foam of nominal density not less than  $65 \text{ Kg/m}^3$  or Polyuretane or balsa wood, or a combination of these.

## D.3 HULL SHELL

### D.3.1 CONSTRUCTION

- (a) The external shape of the **hull** shall comply with these **class rules** and Measurement Diagrams.
- (b) The external **hull** includes:
- (i) bottom panels, **keel**, skeg and optional bilge keels,
  - (ii) side panels and rubbing strakes,
  - (iii) transom.
- (c) Bottom surface shall not have any inflection in the curvature,
- (d) Side panels may have curvature inflections between sections 0 and 2,
- (e) A straight edge 680mm  $\pm$ 25mm long sliding along the sheerline and chine shall not show hollows against the measured surface,
- (f) Rounding off of exposed and internal edges of the **hull** is permitted to a maximum radius of 10mm or the angle may be cut with chamfer of a maximum of 14mm distance between edges, as shown in Diagram D.3.2.1. Angles between **keel** and **skeg** can be filled as shown in Diagram D.3.2.2.,
- (g) False and/or double bottom are prohibited. For the effect of this rule sandwich type construction not thicker than 15mm shall not be considered double bottom.

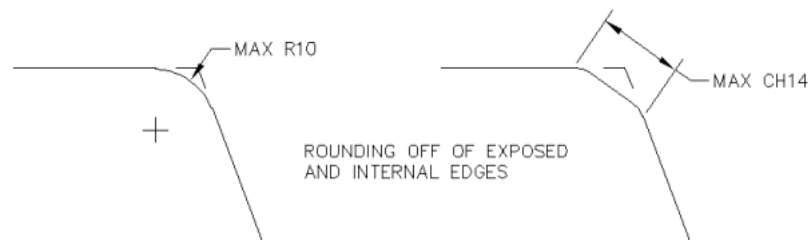

D.3.2.1 DIAGRAM



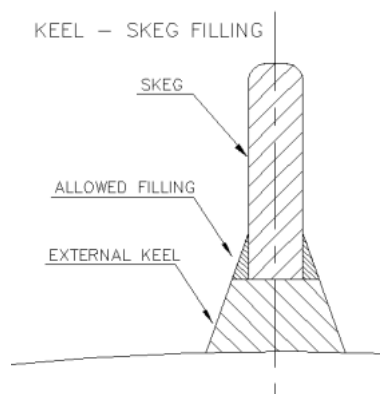

D.3.2.2 DIAGRAM

## D.4 EXTERNAL KEEL, SKEG AND BILGE KEELS

### D.4.1 CONSTRUCTION DETAILS

External **keel** and **skeg** may be faired over a maximum length of 120mm from the aft most side as for fig D.4.4.1. Altering the horizontal thickness of the **keel** at the junction with the stem is permitted.

### D.4.2 EXTERNAL KEEL DIMENSIONS

		minimum	maximum
1	Width at its intersection with the <b>hull</b> shell	52mm	95mm
2	Width of <b>keel</b> bottom side	32mm	
3	Height	28mm	

D.4.3 **Bilge keels** are optional. If used, they shall be positioned between section 2 and 4 and under the optional outer floor battens. They may be faired over a maximum length of 120mm from the aft most side and fore most side.

D.4.4 The dimensions of the **skeg** shall conform to those given in diagram D.4.4.1 and shall be measured with a template as specified in Section I. A maximum of 5mm tolerance is permitted. The thickness shall be between 20mm and 24mm.

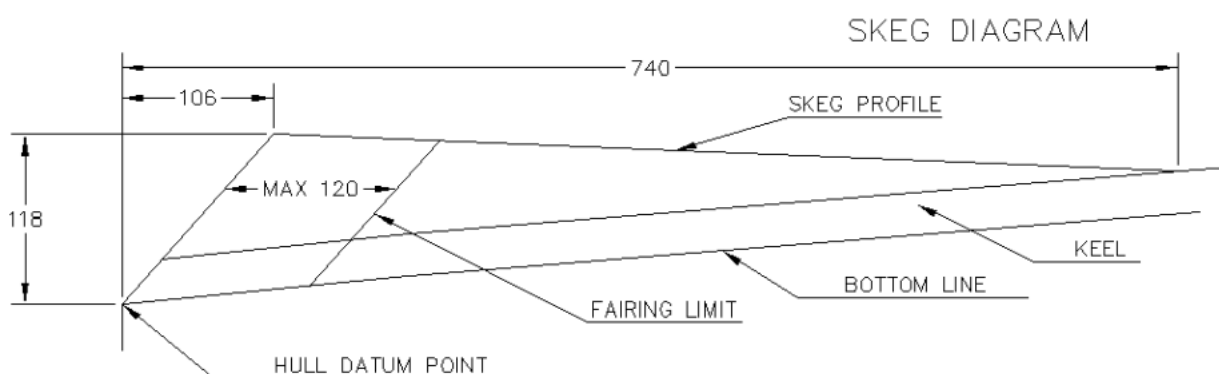

D.4.4.1 - SKEG DIAGRAM

## D.5 TRANSOM AND STEM

### D.5.1 DIMENSIONS

- (a) The bottom shape of the transom shall conform to diagram D.5.1.(a) and shall be measured with the transom bottom shape template as specified in Section I. Measurements in the diagram include minimum and maximum.

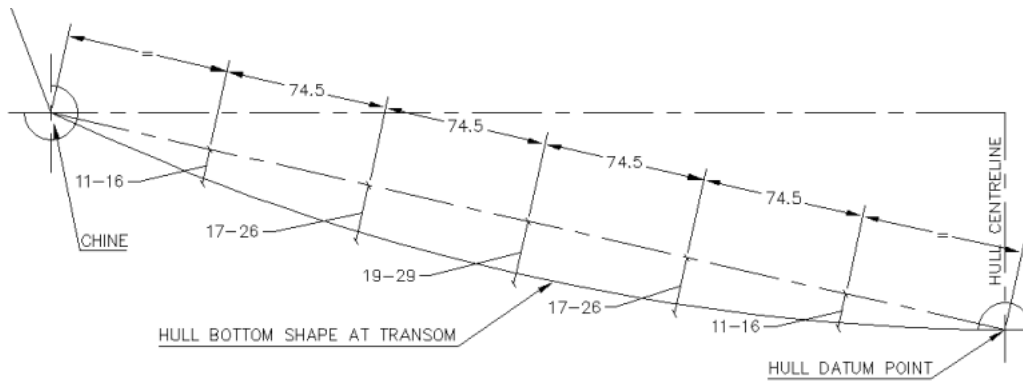

D.5.1(a) - TRANSOM DIAGRAM

- (b) The transom surface shall be flat with a tolerance of  $\pm 5\text{mm}$  as shown on diagrams D.5.1 (b)

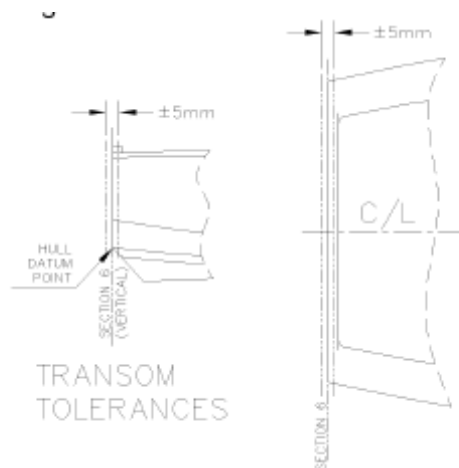

D.5.1 (b) – TRANSOM SURFACE

- (c) The shape of the stem 60mm below FMP1 and FMP2 shall be checked with the template as shown in Section I. Templates shall touch the **hull** on both sides.

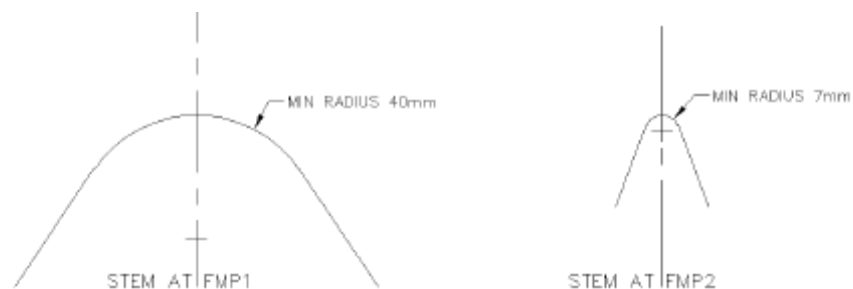

D.5.1(c) - STEM DIAGRAMS

## D.5.2 DRAINAGE PORTS

The transom shall have a maximum of two drainage ports in which case they shall be equidistant from the transom centreline with a maximum tolerance of 2mm. They shall have a minimum total combined area of 1950 mm<sup>2</sup> and be either:

- (a) Circular, as close as possible to the bottom panel, or,
- (b) Of any shape with no dimension exceeding 120 mm in any direction and not less than 15 mm from the outside of the bottom skin.

If the boat is fitted with self-bailer/s the drainage port/s shall have a minimum section area of 760 mm<sup>2</sup>.

## D.6 DECKS

### D.6.1 CONSTRUCTION

- (a) The foredeck shall contain the coamings,
- (b) The foredeck may be prolonged to include the mast thwart,
- (c) No part of the foredeck and side decks shall fall below a straight line connecting sheerlines athwartship,
- (d) Side decks edges may be rounded athwartship.

## D.7 BUOYANCY TANKS

### D.7.1 MATERIALS

- (a) In addition to rule D.2.6 buoyancy tanks shall comply with ISO 12217-3 Annex C.

### D.7.2 CONSTRUCTION

- (a) **Boats** shall be able to withstand a buoyancy test as described in section H1.
- (b) Built-in buoyancy compartments shall be placed under the side decks and the foredeck equally distributed on each side of the boat's centreline and fore and aft. There shall be not less than three compartments with a total minimum volume of 360 litres and the

smallest compartment shall have a volume no less than 100 litres. They may have drain watertight holes with detachable plugs secured to the **hull** against loss.

- (c) **Hulls** manufactured without built-in buoyancy compartments are accepted with inflatable air bags as floatation devices. These shall additionally comply with ISO 12217-3 Annex D. The largest air tank shall not be included as a flotation element. They shall be not less than five and each shall give a minimum positive buoyancy of 350 Newtons. They shall be firmly secured to the **hull** under the sidedecks and the foredeck and they shall be equipped with a non-return valve.
- (d) The compulsory secondary buoyancy shall be provided by the use of a minimum of 100 litres of rigid foam divided into not less than three parts of approximately the same volume and securely attached to the **hull**, one forward of the **mast** and the other two aft of the **mast**, distributed equally on each side of the boat's centreline.
- (e) Built-in buoyancy compartments shall have inspection holes.

## D.8 GUNWALE RUBBING STRAKES

### D.8.1 CONSTRUCTION

- (a) The rubbing strake shall run unbroken on each gunwale,
- (b) The dimensions of the rubbing strakes shall not exceed those given in diagram D.8.2.1 and shall be checked with the template shown in section I.

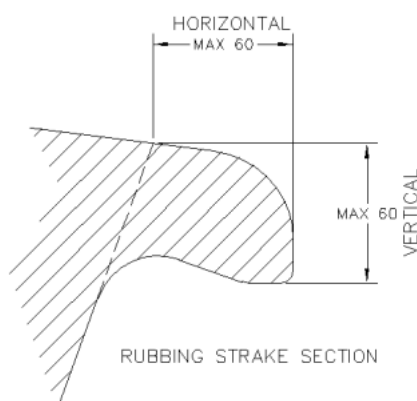

D.8.2.1 – RUBBING STRAKE DIAGRAM

## D.9 BULKHEAD

### D.9.1 CONSTRUCTION

In GRP built **hulls**, the bulkhead shall separate the buoyancy tanks into three compartments.

## D.10 ASSEMBLED HULL

### D.10.1 FITTINGS

#### (a) MANDATORY

The following fittings shall be positioned in accordance with the Diagrams:

- (1) One forestay fitting.
- (2) Two shroud plates.

for the following fittings the position is optional:

- (3) Mast step.
- (4) Two gudgeons or two pintles.
- (5) Toe straps not capable of extending outboard.
- (6) A locking device for preventing the rudder to be dislodged from gudgeons.
- (7) Mainsail sheet blocks, fairleads and cleats.
- (8) Headsail sheet blocks, fairleads and cleats.
- (9) Spinnaker sheet fairleads, blocks and cleats.
- (10) One inspection hole in each buoyancy compartment, provided that the watertight integrity of the buoyancy compartment is maintained and covers are capable of resisting accidental dislodgement, except for buoyancy bags.

#### (b) OPTIONAL

- (1) Halyard tensioners.
- (2) **Mainsail** cunningham blocks, fairleads and cleats.
- (3) **Headsail** cunningham blocks, fairleads and cleats.
- (4) **Headsail** barber hauler fairleads, blocks and cleats.
- (5) Tiller lock.
- (6) Stowage clips for paddle, spinnaker pole, sail bags and other equipment.
- (7) Two self bailers which may discharge through the **hull** shell.
- (8) One magnetic or electronic compass.
- (9) Draining holes in buoyancy compartments, provided that the watertight integrity of the buoyancy compartment is maintained and plugs are capable of resisting accidental dislodgement, except for buoyancy bags.
- (10) Two spinnaker bags.
- (11) Kicking strap adjustment devices.
- (12) Any sealing strips for the centreboard slot..
- (13) Any adjusting system for the centreboard position at top and/or bottom of the centreboard case.
- (14) Laths placed inside the centreboard case to control the lateral play of the centreboard.
- (15) Hinged covers or other devices for closing the draining ports or drains in the transom.

## D.10.2 DIMENSIONS

## (a) GENERAL

The sections shall be taken as vertical, transverse planes at the following positions :

Section 0 : at FMP2

Section 2 : at 2720mm from **hull datum point (HDP)**

Section 4 : at 1360mm from **hull datum point**

Section 6 : at **hull datum point**

## (b) HULL MEASUREMENTS

		minimum	maximum
1	<b>Hull length</b>	4060mm	4100mm
	Beam of <b>hull</b> , excluding rubbing strakes and fittings, between sheerlines:		
2	at section 2	1262mm	1282mm
3	at section 4	1444mm	1464mm
4	at section 6	1030mm	1050mm
5	Longitudinal distance from <b>hull datum point</b> to forward side of mast notch in mast thwart	2705mm	2735mm
6	Longitudinal dimension of mast spar thwart forward of notch	70mm	
7	Longitudinal distance between forward side of notch in mast thwart and centre of hole in forestay fitting	1175mm	1185mm
8	Longitudinal distance from <b>hull datum point</b> to centre of shroud plate hole	2250mm	2320mm
	Gunwale rubbing strakes:		
9	Horizontal		60mm
10	Vertical		60mm
11	Diameter of buoyancy compartment holes	100mm	
12	Internal diameter of buoyancy compartment draining holes	25mm	
13	Distance between <b>hull datum point</b> and intersection of Coamings	3380mm	3420mm
14	Distance between <b>hull datum point</b> and aft side of centreboard case	2065mm	2095mm
15	Internal length of centreboard slot		360mm
16	Width of centreboard slot		28mm
17	Height of upper edge of centreboard case and upper side of main thwart at boat centreline above external keel	324mm	334mm
18	Distance between transom and aft end of coamings	2550mm	2650mm
	Width of deck excluding thickness of rubbing strakes:		

		minimum	maximum
19	at section 6	120mm	140mm
20	at section 4	150mm	170mm
21	at section 2	180mm	200mm
22	Width of notch in mast thwart		70mm
23	Distance of any holes in mast thwart from centreline	35mm	
24	Depth of mast thwart at notch from sheerline	11mm	21mm
25	Length of mast thwart aft of the forward leading edge of the mast notch	100mm	
26	Length of main thwart	150mm	
27	Width of side benches	150mm	
28	Side benches rounding off radius		150mm
29	Length of side benches	1060mm	
30	Depth of side benches from main thwart upper face		25mm
31	Height of coamings from deck at boats centreline	20mm	
32	Height of coamings at 50 mm from sheerline	5mm	
33	Distance from HDP to FMP2	4005mm	4045mm
34	Horizontal distance between FMP1 and FMP 2	50mm	55mm
35	Vertical distance between FMP1 and FMP 2	505mm	515mm
36	Distance between aft of centreboard slot and HDP	2015mm	2045mm
37	Vertical distance from baseline to bottom line at section 2	60mm	80mm
38	Vertical distance from baseline to bottom line at section 4	58mm	68mm
39	Longitudinal distance from <b>hull datum point</b> to aft edge of main thwart	1865mm	1895mm
40	Hull beam between chines :		
41	at section 2	866mm	886mm
42	at section 4	1144mm	1164mm
43	at section 6	862mm	882mm
44	Vertical distance of any point of the bottom at section 2 from the reference line from chine to chine		10mm
45	Height of chines above <b>keel</b> at transom	93mm	103mm
46	Distance between chine and sheerline at section 6	224mm	234mm
47	Distance between chine and sheerline at section 4	427mm	437mm
48	Distance between chine and sheerline at section 2	524mm	534mm

		minimum	maximum
49	Side panels at section 6,4 and 2 shall be straight with a tolerance of		5mm

## D.10.3 WEIGHT

		minimum	maximum
	<b>Hull weight</b>	70kg	

The **hull** shall be weighed without any appendages, **rigging**, **spars**, **sails** as well as movable fittings or apparatuses, fixed fittings may be left in place.

## D.10.4 HULL CORRECTOR WEIGHTS

- (a) A maximum of two corrector weights shall be permanently fastened to the inside of the hull transom when the **hull** weight is less than the minimum requirement.
- (b) The total weight of such corrector weights shall not exceed 3 kg.





D.10.6 DIAGRAM 2

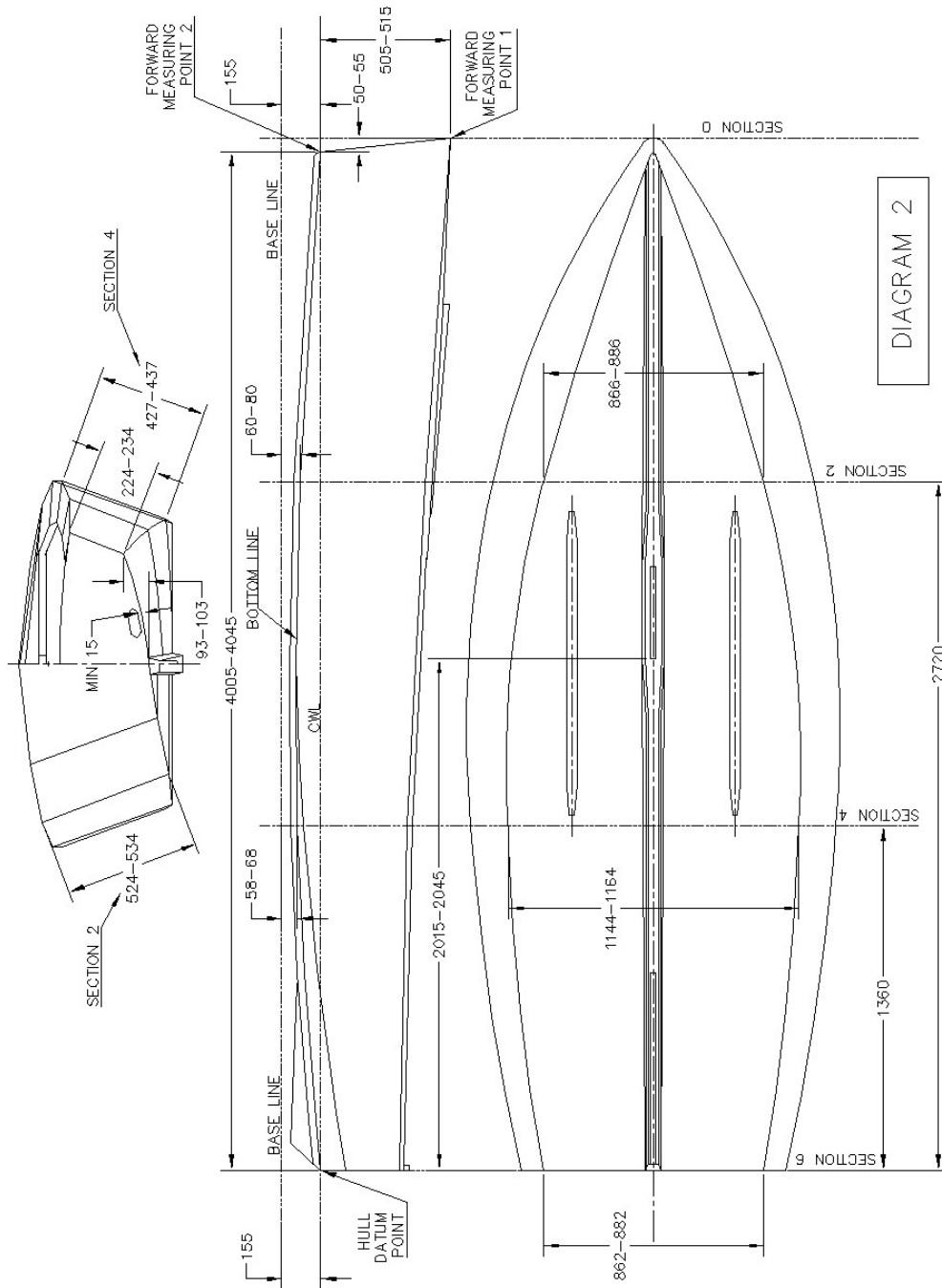

## Section E – Hull Appendages

### E.1 PARTS

#### E.1.1 MANDATORY

- (a) **Centreboard,**
- (b) **Rudder.**

### E.2 GENERAL

#### E.2.1 RULES

- (a) **Hull appendages** shall comply with the **class rules** in force at the time of **certification**.

#### E.2.2 CERTIFICATION

- (a) The **official measurer** shall **certify hull appendages** and shall sign and date the **certification mark**,
- (b) An ISAF In-House Certification (IHC) Authorising Authority may appoint one or more Internal Official Measurers at a manufacturer to measure and certify hull appendages produced by this manufacturer, in accordance to ISAF IHC guidelines.

#### E.2.3 MANUFACTURERS

No licence is required.

### E.3 CENTREBOARD

#### E.3.1 MATERIALS

- (a) The **centreboard** shall be of materials as specified for the **hull** in D.3.1.
- (b) No metal inserts are permitted.

#### E.3.2 FITTINGS

##### (a) MANDATORY

- (1) Any handhold.
- (2) A centreboard stopper made of any material situated at a maximum of 30mm from the trailing edge as shown in E.3.3.1.

##### (b) OPTIONAL

- (1) Any lath and/or strips may be fitted to the upper part of the **centreboard**.

#### E.3.3 DIMENSIONS

- (a) The dimensions of the **centreboard** shall not exceed those given on the diagram E.3.3.1.

## CENTREBOARD MAXIMUM DIMENSIONS

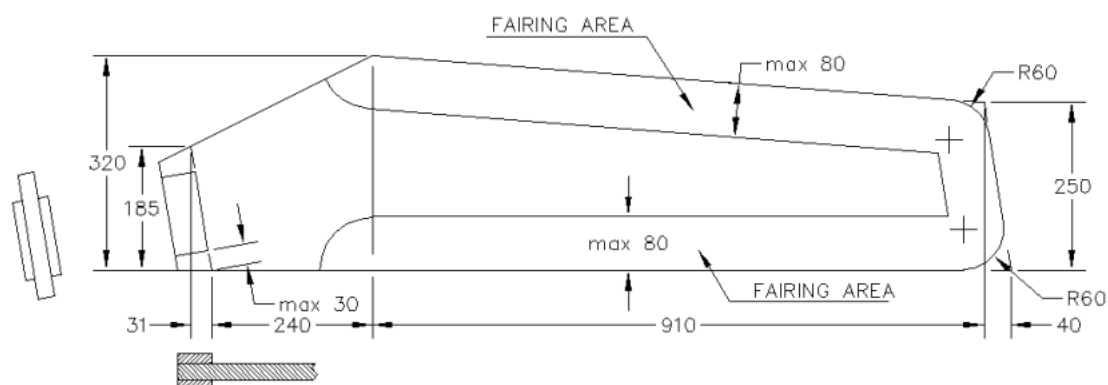

E.3.3.1. CENTREBOARD DIAGRAM

- (b) The thickness of the **centreboard** shall not vary more than 1mm, and shall be of a minimum thickness of 18mm except that the edges may be faired over a maximum distance of 80mm from the trailing, leading and lower edges as shown in E.3.3.1
- (c) The **centreboard** shall not be pierced by lightening holes.
- (d) The **centreboard** trailing edge shall be straight with a maximum deviation of an edge from a straight line of 10mm.

## E.3.4 WEIGHT

The **centreboard** with fittings shall have positive buoyancy when immersed in fresh water.

## E.4 RUDDER BLADE, RUDDER HEAD AND TILLER

## E.4.1 MATERIALS

- (a) The **rudder** blade shall be of materials as specified for the **hull** in D.3.1.
- (b) Rudder head, tiller and tiller extension may be of any material.

## E.4.2 CONSTRUCTION

- (a) The rudder blade may be able to pivot around a horizontal axis in which case it shall include any system to lift the blade from its lowered position.
- (b) The tiller extension may be of any type.

## E.4.3 FITTINGS

- (a) MANDATORY  
Any two gudgeons or two pintles.

## E.4.4 DIMENSIONS

- (a) The dimensions of the rudder blade shall not exceed those given on the diagram E.4.4.1. Below the dashed line the rudder blade edges shall be within 10mm from the maximum permissible dimensions.
- (b) The thickness of the rudder blade shall not vary more than 1mm and shall be of a minimum thickness of 18mm. except that the

edges may be faired over a maximum distance of 80mm from the trailing, lower and leading edges as showing in Figure E.4.4.1.

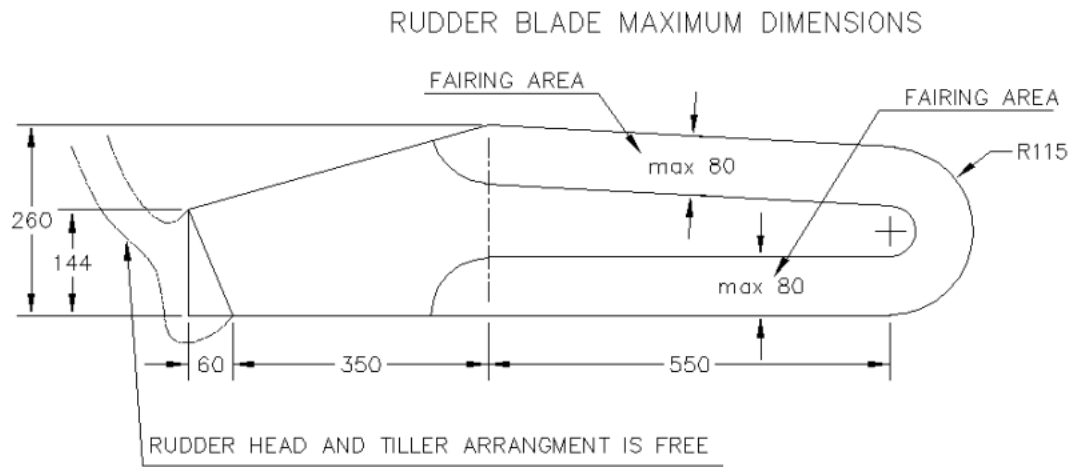

E.4.4.1. RUDDER DIAGRAM

## Section F – Rig

### F.1 PARTS

#### F.1.1 MANDATORY

- (a) **Mast**
- (b) **Boom**
- (c) Standing **rigging**
- (d) Running **rigging**

#### F.1.2 OPTIONAL

- (a) **Spinnaker pole**

### F.2 GENERAL

#### F.2.1 RULES

- (a) The **spars** and their fittings shall comply with the **class rules** in force at the time of **certification** of the **spar**,
- (b) The **standing** and **running rigging** shall comply with these **class rules**.

#### F.2.2 MODIFICATIONS AND REPAIRS

- (a) **Spars** shall not be altered in any way except as permitted by these **class rules**.

#### F.2.3 CERTIFICATION

- (a) The official measurer shall certify **spars** and shall sign and date the **certification mark**.
- (b) An ISAF In-house Certification (IHC) Authorizing Authority may appoint one or more Internal Official Measurers at a manufacturer to measure and certify **spars** produced by that manufacturer in accordance with the ISAF IHC guidelines.
- (c) No **certification** of **standing and running rigging** is required.

#### F.2.4 DEFINITIONS

##### (a) LIMIT MARKS

Limit marks shall be painted or indelibly marked on the **spars** in a contrasting colour 10mm minimum wide. Tape is not permitted.

The **mast datum point** is the lower edge of band n°1.

**Lower limit mark** is band n°2.

**Upper limit mark** is band n°3.

#### F.2.5 MANUFACTURER

- (a) No licence is required.

### F.3 MAST

#### F.3.1 MATERIALS

- (a) The **mast spar** shall be made of aluminium alloy.

### F.3.2 CONSTRUCTION

- (a) The **spar** extrusion shall include a fixed sail groove or a fixed track which may not be integral with the **spar** but shall be of the same material,
- (b) Cleats shall not be fixed on the mast spar above the **lower limit mark**,
- (c) Fairleads or conduits may be used for guiding **halyards**, but they shall not be placed higher than 3400mm above the **mast datum point**,
- (d) The **mast spar** shall be of constant cross-section throughout its length except between the upper edge of the **lower point** and a point no more than 300mm above it.

### F.3.3 FITTINGS

#### (a) MANDATORY

- (1) Mast head fitting.
- (2) Shroud tangs or similar.
- (3) **Mainsail** halyard sheave.
- (4) **Headsail** halyard sheave.
- (5) Gooseneck.
- (6) Kicking strap attachments.
- (7) Heel fitting.

#### (b) OPTIONAL

- (1) Spinnaker halyard sheave or fairlead.
- (2) Spinnaker pole fitting.
- (3) Spinnaker pole lift block or fairlead.
- (4) Spinnaker pole downhaul block or fairlead.
- (5) Two **spreaders**.
- (6) One mechanical wind indicator.
- (7) Compass bracket.
- (8) Fairleads for guiding running rigging lines.
- (9) Wedges and/or chocks for positioning the mast between the partners.
- (10) Multiple hooks for main **halyard**.
- (11) Electronic or mechanical compass.
- (12) Timing device.
- (13) A fitting for preventing the mainsail from being set above the upper point to ensure compliance with C.10.3 (b)(2).
- (14) The area between the **mast** and the mast partners may be protected with any material.

## F.3.4 DIMENSIONS

		minimum	Maximum
1	<b>Mast length</b>		6300mm
	<b>Mast spar cross section</b> between the <b>mast top point</b> and the <b>mast heel point</b> excluding fittings and the groove opening section		
	<b>Fore and aft</b>	46mm	
	<b>Transverse</b>	46mm	
2	<b>Mast Datum Point to lower point</b>	605mm	607mm
5	<b>lower point to upper point</b>		5100mm
6	<b>Lower Point</b> to lowest point of the groove		300mm
7	<b>Forestay and shroud height</b>	4106mm	4149mm
8	Distance of spinnaker <b>halyard</b> turning point from fore face of mast		100mm
9	Spinnaker pole fitting length from foreface of <b>mast</b>		40mm
10	Height of spinnaker halyard turning point from <b>mast datum point</b>	4130mm	4222mm
11	<b>Spreader height</b>	2179mm	2233mm

## F.3.5 WEIGHT

		minimum	Maximum
	<b>Mast weight</b>	7kg	

The weight of the **mast** shall include rigging specified under F.6.2, F.7.2 (a)(1), F.7.2(a)(4), F.7.2(b)(5), F.7.2(b)(7), F.7.2 (b)(8) and fittings specified under F.3.3, but excluding wind indicator, compass or timing device.

If the **mast** weight is less than the minimum required, a maximum of 0.5Kg of corrector weights shall be permanently fastened to the **mast** at its centre of gravity.



F.3.6 MAST DIAGRAM

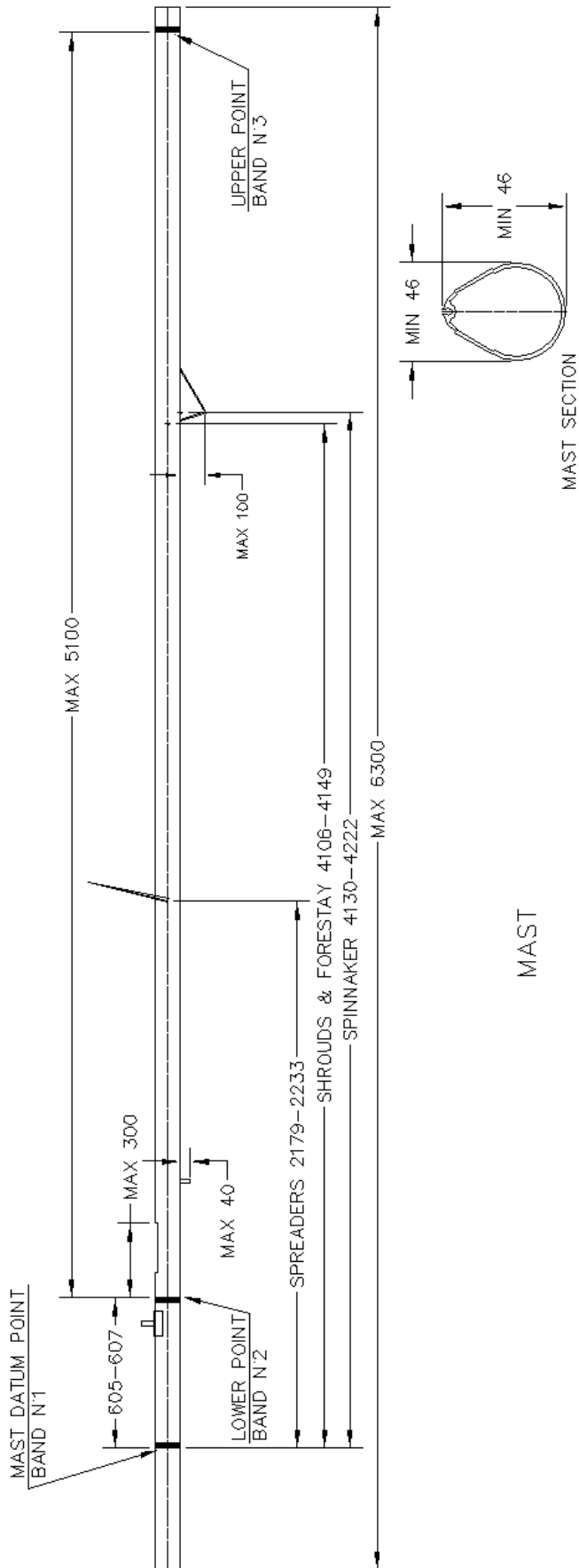

## F.4 BOOM

### F.4.1 MATERIALS

(a) The **spar** shall be of aluminium alloy.

### F.4.2 CONSTRUCTION

(a) The **spar** extrusion shall include a fixed sail groove or track which may not be integral with the **spar** but shall be of the same material.

(b) The **spar** aft end may be cut below its half height, maximum 300mm from the outboard end.

### F.4.3 FITTINGS

#### (a) MANDATORY

(1) One single sheave mainsheet block with attachments.

(2) Any clew outhaul blocks and any attachments.

(3) Kicking strap fitting.

(4) Gooseneck attachment.

#### (b) OPTIONAL

(1) Not more than two wire strops for mainsheet blocks.

(2) Spinnaker pole stowage fittings.

(3) Two single sheaves or a double sheave block for mainsheet with attachment fittings.

(4) A system to adjust mainsail clew position.

(5) Fitting to attach mainsail tack to boom.

(6) The **boom** may be protected in the area where it touches the shrouds by pieces of any material and dimensions, provided they do not alter the stiffness of the boom spar.

(7) The use of shock cord to hold out the boom is permitted provided it does not alter the sail plan.

### F.4.4 DIMENSIONS

		minimum	Maximum
	<b>Boom Spar Cross Sections:</b>		
1	<b>Vertical</b> including groove or track		90mm
2	<b>Transverse</b>	32mm	
3	Boom Length		2600mm

### F.4.5 WEIGHT

No weight limitations apply.

#### F.4.6 BOOM DIAGRAM

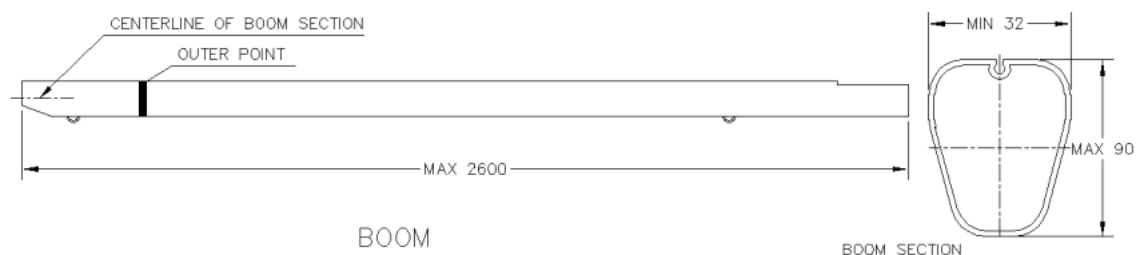

### F.5 SPINNAKER POLE

#### F.5.1 MATERIALS

(a) The **spar** shall be made of aluminium alloy.

#### F.5.2 FITTINGS

(a) OPTIONAL

1. One hook at each end.
2. Fittings approximately at the mid-point for attachment for lift and downhaul lines.
3. A fixed line between the fittings described in F.5.3 (a) (1), which may incorporate knots, toggles or short tubes.

#### F.5.3 DIMENSIONS

		Minimum	Maximum
1	<b>Spinnaker pole cross section</b> at mid length	25 mm	
2	<b>Spinnaker pole length</b> including hooks		1750 mm

### F.6 STANDING RIGGING

#### F.6.1 MATERIALS

(a) The **standing rigging** shall be of stainless steel.

#### F.6.2 CONSTRUCTION

(a) MANDATORY

- (1) A **forestay**.
- (2) Two **shrouds**.

#### F.6.3 FITTINGS

(a) MANDATORY

- (1) **Forestay** steel rigging link.
- (2) **Shroud** steel rigging links.

#### F.6.4 DIMENSIONS

(a)

		Minimum	Maximum
1	<b>Forestay</b> diameter	2,5 mm	
2	<b>Shroud</b> diameter	2,5 mm	

(b) No length limitations apply.

F.6.5 WEIGHT

No weight limitations apply.

**F.7 RUNNING RIGGING**

F.7.1 MATERIALS

(a) Materials are optional

F.7.2 CONSTRUCTION

(a) MANDATORY

- (1) Mainsail halyard.
- (2) Mainsail sheet.
- (3) Kicking strap.
- (4) Headsail halyard.
- (5) Headsail sheets.

(b) OPTIONAL

- (1) Mainsail cunningham line.
- (2) Mainsail outhaul.
- (3) Headsail cunningham line.
- (4) Single line headsail barber haulers.
- (5) Spinnaker halyard.
- (6) Spinnaker sheets.
- (7) Spinnaker pole lift.
- (8) Spinnaker pole downhaul.
- (9) Spinnaker barber haulers.

F.7.3 FITTINGS

(a) MANDATORY

- (1) Mainsail sheet cleat or ratchet block.
- (2) Headsail sheets fairleads and cleats.

(b) OPTIONAL

- (1) One eye or single sheave in each headsail barber hauler to run on headsail sheet.
- (2) One eye or single sheave in each spinnaker barber hauler to run on spinnaker sheet.
- (3) Spinnaker sheets fairleads and cleats.

F.7.4 DIMENSIONS

No length limitations apply

F.7.5 WEIGHT

No weight limitations apply.

## Section G – Sails

### G.1 PARTS

#### G.1.1 MANDATORY

- (a) **Mainsail**
- (b) **Headsail**

#### G.1.2 OPTIONAL

- (a) Spinnaker.

### G.2 GENERAL

#### G.2.1 RULES

- (a) **Sails** shall comply with the **class rules** in force at time of **certification**.

#### G.2.2 CERTIFICATION

- (a) The **official measurer** shall **certify mainsails** and **headsails** in the **tack** and spinnakers in the **head** and shall sign and date the **certification mark**.
- (b) An ISAF In-house Certification (IHC) Authorizing Authority may appoint one or more Internal Official Measurers at a sailmaker to measure and certify sails produced by that manufacturer in accordance with the ISAF IHC guidelines.

#### G.2.3 SAILMAKER

- (a) No licence is required.
- (b) The date of manufacture, type and weight in  $\text{g/m}^2$  of the **body of the sail** shall be indelibly marked near the **head point** by the sailmaker together with the date and his signature or stamp.

### G.3 MAINSAIL

#### G.3.1 IDENTIFICATION

- (a) The class insignia shall conform to the dimensions and requirements as detailed in the diagram contained in G.3.1.1 with a tolerance of  $\pm 10$  mm, be of a contrasting colour, and be placed in accordance with the following provisions:
  - (1) The corners may be rounded off.
  - (2) It shall be placed back to back with the "flag" pointing to the leech, above the **three-quarter leech point batten pocket** and not more than 100mm from its upper edge.

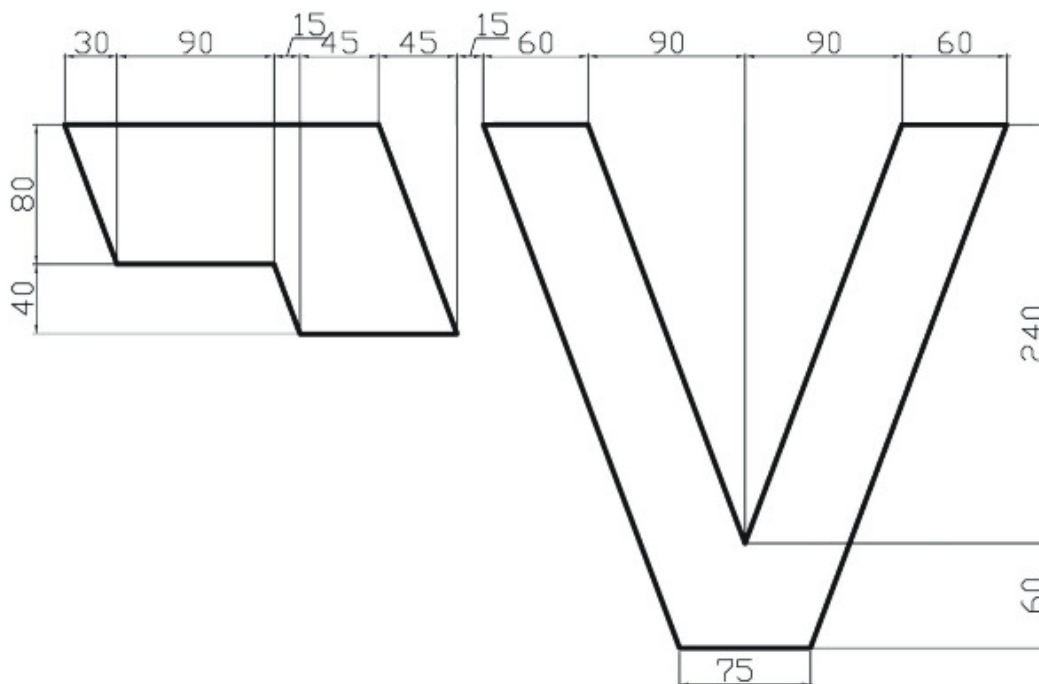

DIAGRAM G.3.1.1

### G.3.2 MATERIALS

- (a) The **ply** fibres shall be made of polyester,
- (b) Battens may be made of any material,
- (c) The boltrope shall be made of synthetic fibre and not be shockcord.

### G.3.3 CONSTRUCTION

- (a) The construction shall be: **soft sail, single ply sail**,
- (b) The **body of the sail** shall consist of the same **woven ply** throughout, except for the window and the foot panel,
- (c) The **sail** shall have a minimum of three and a maximum of four **batten pockets** in the **leech**,
- (d) The following are permitted: stitching, glues, tapes, bolt ropes, three corner eyes, headboard with fixings, cunningham eye or attachment, cunningham rope, **batten pocket patches**, batten pocket elastic, batten pocket end caps, mast and boom slides, one **window**, tell tales, sail shape indicator stripes, tensioning devices at leech end of the two upper battens, leech lines,
- (e) The **leech** shall not extend aft of straight lines between:
  - (1) the **aft head point** and the intersection of the **leech** and the upper edge of the nearest **batten pocket**.
  - (2) the intersection of the **leech** and the lower edge of a **batten pocket** and the intersection of the **leech** and the upper edge of an adjacent **batten pocket** below.
  - (3) the **clew point** and the intersection of the **leech** and the lower edge of the nearest **batten pocket**.

(f) The **leech** shall be edged by a **tabling**.

#### G.3.4 DIMENSIONS

		<b>Minimum</b>	<b>Maximum</b>
1	<b>Leech length</b>	5100 mm	5350 mm
2	Extension of headboard from <b>head point</b>		150mm
3	<b>Three-quarter width</b>		1050mm
4	<b>Half width</b>		1640mm
5	<b>Primary reinforcement</b>		305 mm
	<b>Secondary reinforcement</b>		
6	<b>Flutter patch</b>		120 mm
7	<b>Chafing patch</b>		300 mm
8	<b>Batten pocket patch</b>		175 mm
9	Any other <b>secondary reinforcements</b>		915 mm
10	<b>Tabling width</b>		35 mm
11	Distance from <b>clew point</b> to <b>foot</b> bolt rope		300 mm
12	Distance from <b>tack point</b> to <b>foot</b> and <b>luff</b> bolt ropes		300 mm
13	Diameter of bolt rope	6mm	
14	<b>Seam width</b>		30 mm
15	If <b>batten pocket</b> overlaps a panel <b>seam</b> the panel <b>seam</b> width		50mm
16	<b>Window</b> area		0.15 m <sup>2</sup>
17	<b>Window</b> to <b>sail edge</b>	150 mm	
	<b>Batten pocket length:</b>		
18	<b>Outside quarter leech point batten pocket</b> and <b>half leech point batten pocket</b>		700 mm
19	<b>Outside batten pocket width</b>		50 mm
20	<b>Head point</b> to intersection of <b>leech</b> and centreline of <b>upper leech point batten pocket</b> for sails with 4 battens	450 mm	500 mm
21	<b>Head point</b> to intersection of <b>luff</b> and centreline of <b>upper leech point batten pocket</b> for sails with 4 battens		350 mm
22	<b>Head point</b> to intersection of <b>luff</b> and centreline of <b>three-quarter leech point batten pocket</b>	1200 mm	1250 mm
23	Distance from the intersection of the centreline of the <b>batten pockets</b> and their closest leech points		40 mm

G.3.5 MAINSAIL DIAGRAM

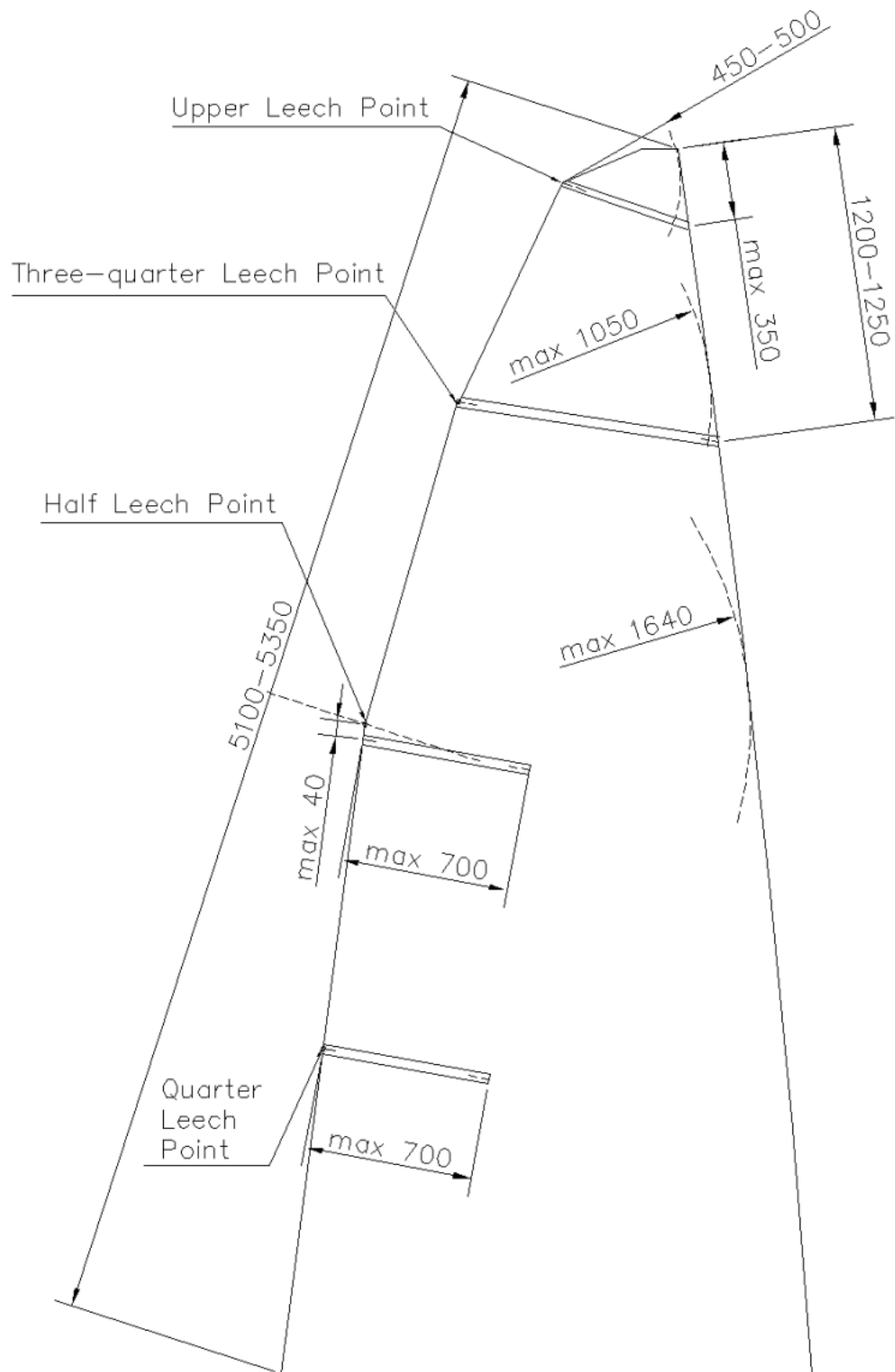



## G.4 HEADSAIL

### G.4.1 MATERIALS

- (a) The **ply** fibres shall consist of polyester,
- (b) The **luff** wire shall be made of a minimum of 7 strand stainless steel wire or of synthetic fibre.

### G.4.2 CONSTRUCTION

- (a) The construction shall be: **soft sail, single ply sail**,
- (b) The **body of the sail** shall consist of the same **woven ply** throughout, except for the **window**,
- (c) The following are permitted: stitching, glues, tapes, corner eyes, hanks, tell tales, flutter patches, one **window**, sail shape indicator stripes, leech lines,
- (d) The **leech** shall not extend beyond a straight line from the **aft head point** to the **clew point**,
- (e) The **leech** and the **foot** shall be edged by a **tabling**.

### G.4.3 DIMENSIONS

		Minimum	Maximum
1	<b>Luff length</b>		3750 mm
2	<b>Leech length</b>		3400 mm
3	<b>Foot length</b>		1650 mm
4	<b>Half width</b>		850 mm
5	<b>Top width</b>		50 mm
6	<b>Foot irregularity</b>		10 mm
7	<b>Primary reinforcement</b>		260 mm
	<b>Secondary reinforcement</b>		
8	<b>Chafing patch</b>		300 mm
9	<b>Any other secondary reinforcements</b>		780 mm
10	<b>Window area</b>		0.15 m <sup>2</sup>
11	<b>Window to sail edge</b>	150 mm	
12	Stainless steel luff wire diameter	2.5 mm	
13	Synthetic fibre luff wire diameter	4 mm	
14	<b>Seam width</b>		30 mm
15	<b>Tabling width</b>		35 mm

## G.4.4 HEADSAIL DIAGRAM

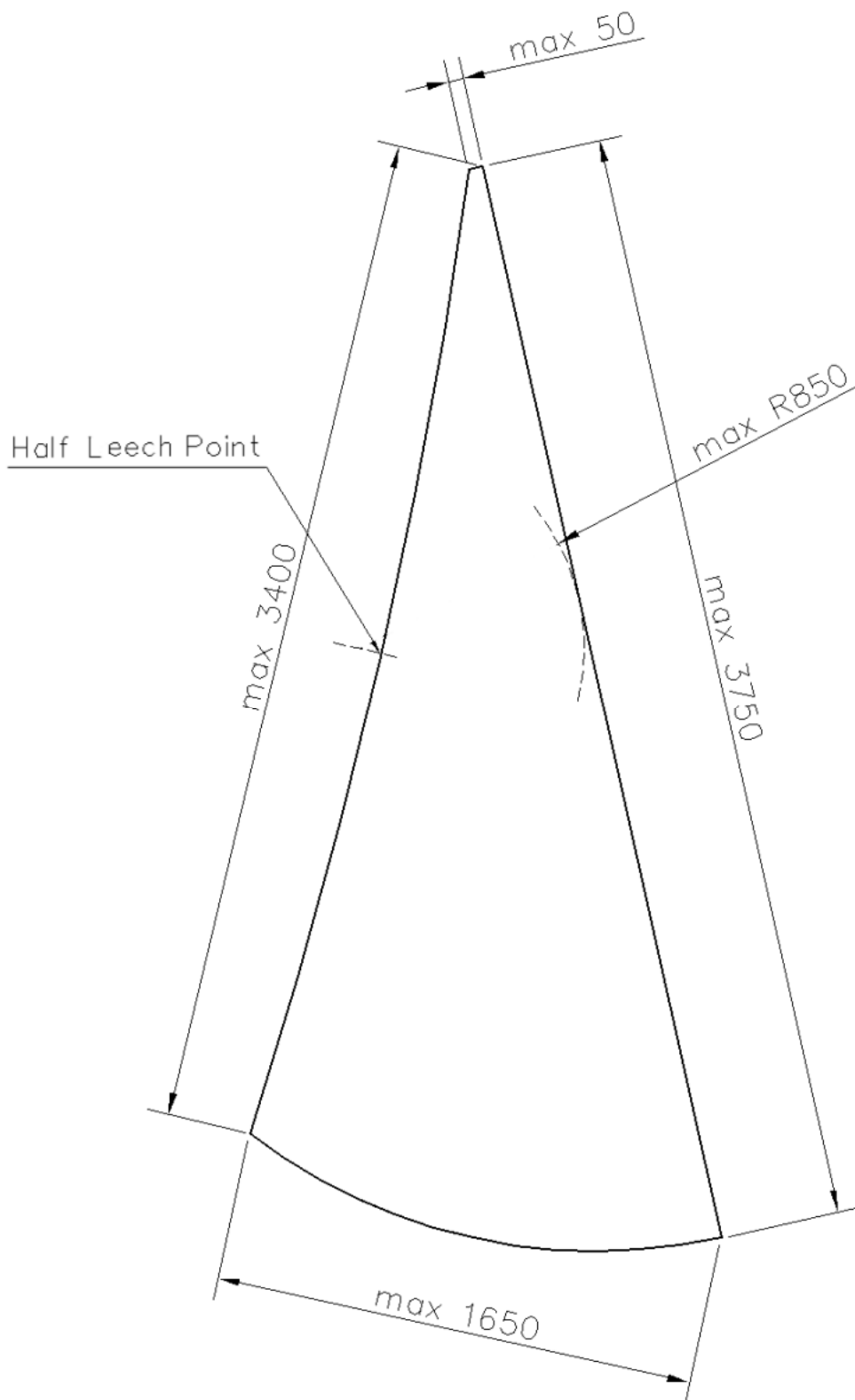

## G.5 SPINNAKER

### G.5.1 MATERIALS

(a) The **ply** fibres shall consist of polyester or nylon.

### G.5.2 CONSTRUCTION

(a) The construction shall be: **soft sail, single ply sail**,

(b) The **body of the sail** shall consist of the same **woven ply** throughout,

(c) The following are permitted: stitching, glues, tapes, corner eyes, recovery line eyes, tell tales,

(d) The **leeches** and the **foot** shall be edged by a **tabling**.

### G.5.3 DIMENSIONS

		Minimum	Maximum
1	<b>Leech lengths</b>		4000 mm
2	<b>Foot length</b>		2400 mm
3	<b>Half width</b>		2650 mm
4	<b>Primary reinforcements</b>		260 mm
5	<b>Secondary reinforcements</b>		780 mm
6	<b>Tabling width</b>		30 mm
7	<b>Seam width</b>		30 mm

G.5.4 SPINNAKER DIAGRAM

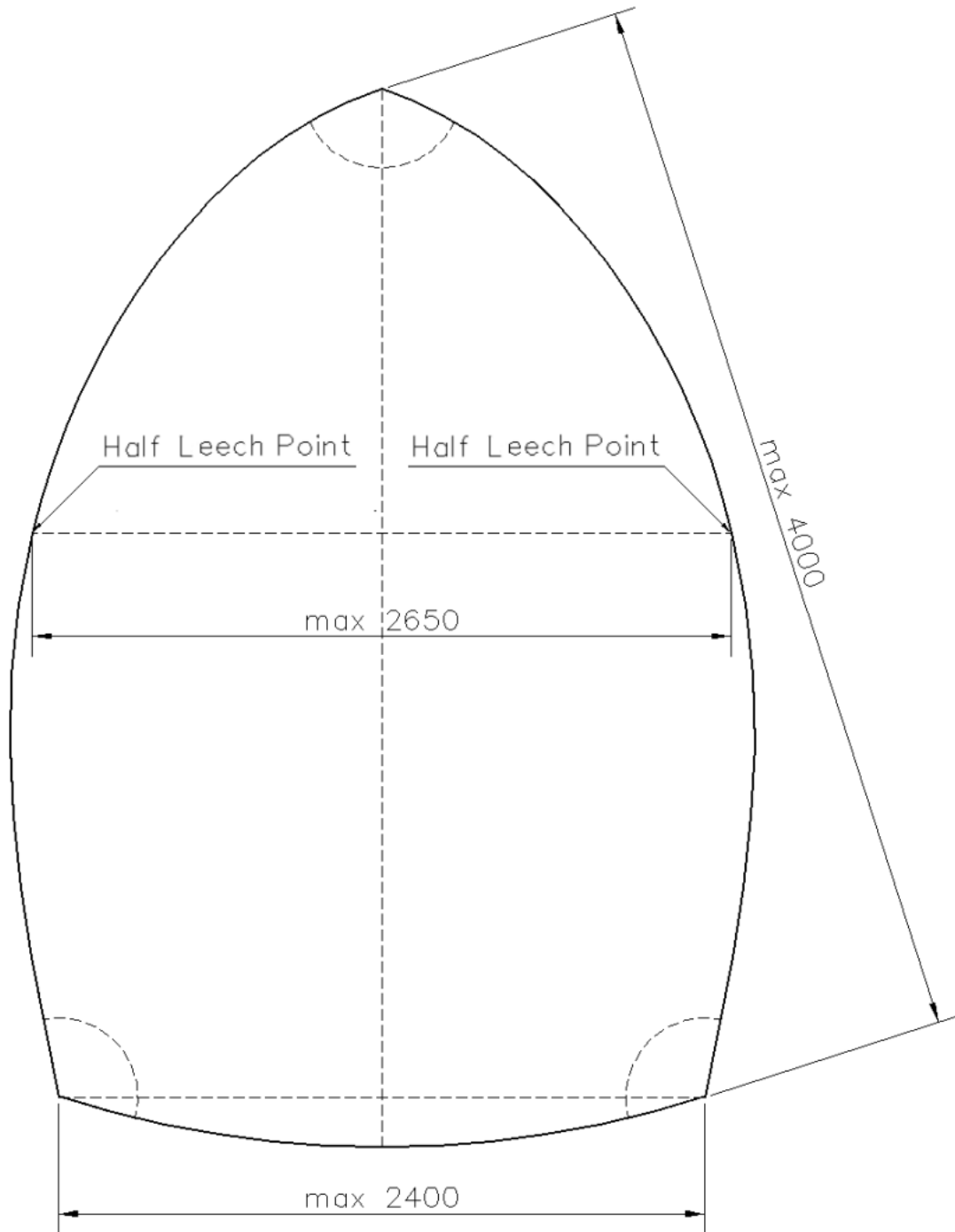

## PART III – APPENDICES

---

The rules in Part III are **closed class rules**. Measurement shall be carried out in accordance with the ERS except where varied in this Part.

### Section H – Buoyancy test

#### H.1 BUOYANCY TEST

The measurer shall witness a buoyancy test as follows :

- the **boat** shall be swamped with water and with weights of not less than 100kg total placed at midship,
- the **boat** shall float with the gunwales clear of the water.

The measurer shall make sure that the buoyancy compartments and their covers as well as drain plugs are safely fastened or, if equipped with air inflated buoyancy, that there are no visible signs of deflation, deterioration or damage.

# Section I – Templates

## I.1 TEMPLATES

